

CAPACITIVE SENSOR

WCS-300



Introduction

Thank you for choosing our CAPACITIVE SENSOR WCS-300. To ensure the correct and efficient functioning of WCS-300, read this manual completely and attentively to understand how to operate the product, before putting it into operation.

About this Manual

- 1 - This manual must be delivered with equipment to its owner;
- 2 - The contents of this manual are subject to change without notice;
- 3 - All rights reserved. No part of this manual may be copied, reproduced, republished, transmitted or distributed for any purpose, without prior written consent of Wirebus;
- 4 - The specifications contained in this manual are limited to the standard models and do not include special products (custom);
- 5 - All precautions were taken on preparing this manual, in order to guarantee the quality of its information..

WARNING!

The instrument described in this technical user manual is a device suitable for application in a specialized technical area. Wirebus supplied products are submitted to a strict quality control process. However, industrial control electronic equipment can cause damage to machinery or processes controlled by them in the event of any failure or improper operations and may even endanger human lives. The user is responsible for setting and selecting values of the parameters of the instrument. The manufacturer warns of the risks of incidents with injuries to both people and goods, resulting from the incorrect use of the instrument.

Table of Contents

PRESENTATION	4
TYPICAL APPLICATIONS	4
TECHNICAL SPECIFICATIONS.....	5
Items Included	5
HOW TO SPECIFY	5
DIMENSIONS	6
OPERATION.....	7
MECHANICAL INSTALLATION	8
ELECTRICAL INSTALLATION	10
WCS-300	10
WCS-300/OPT.....	11
ADJUSTMENT.....	11
WARRANTY	12

Presentation

The capacitive sensor WCS-300 was specially developed for operation with shredded sugar cane, detecting levels.

Built with polypropylene casing and encapsulated in polyurethane resin, the WCS-300 is a sensor waterproof and recommended for harsh environments.

The sensitivity adjustment wide range, easy access, makes it a reliable detection device with great capacity to distinguish between waste and the material to be detected.

The available options for output are: open collector and digital voltage level.

Using up to 10 WCS-300 with our Converter/Adder WAC-510, have an efficient Chute-Donnelly level transmitter.



Typical Applications

The WCS-300 was developed for use with cane sugar, but shows great results in the detection of various materials such as:

- fruits;
- cereals;
- rations;
- fertilizers;
- sugar;
- oils;
- conductive liquids or not;
- cement;
- organic materials;
- can even be used as a proximity alarm.

Technical Specifications

Type	Test Conditions
Sensibility	Adjustable from 0 to 50 mm (internal trimpot)
Indication	"LED"
Out	SC-500: NPN (OC) and PNP (VL) maximum 100mA SC-500/OPT: 12 – 30 V (there is no polarity) maximum 100mA
Power Consumption	0,7 VA
Input Voltage	12 - 30 Vdc
Electronic Unit Operating Temperature	0°C - 85°C
IP Protection	IP-65
Construction	Housing: Polyamide Cover: "Sangel" Strap Cover: Polypropylene
Connection	Directly to the unit to be measured by flange. M6 fixing kit included
Aprox. Weight	0,3 kg

Items Included

Item	Description	Qty
1	M6 X 20 Stainless Allen Button Head Screw Bolt	3
2	M6 Stainless Spring Washer	3
3	M6 Stainless Flat Washer	3

How to Specify

WCS-300 / _____	
Output	NPN or PNP output.
OPT	Optocoupler output.

Exemple: **WCS-300**: Capacitive Sensor with NPN or PNP output.

WCS-300/OPT: Capacitive Sensor with optocoupler output.

Dimensions

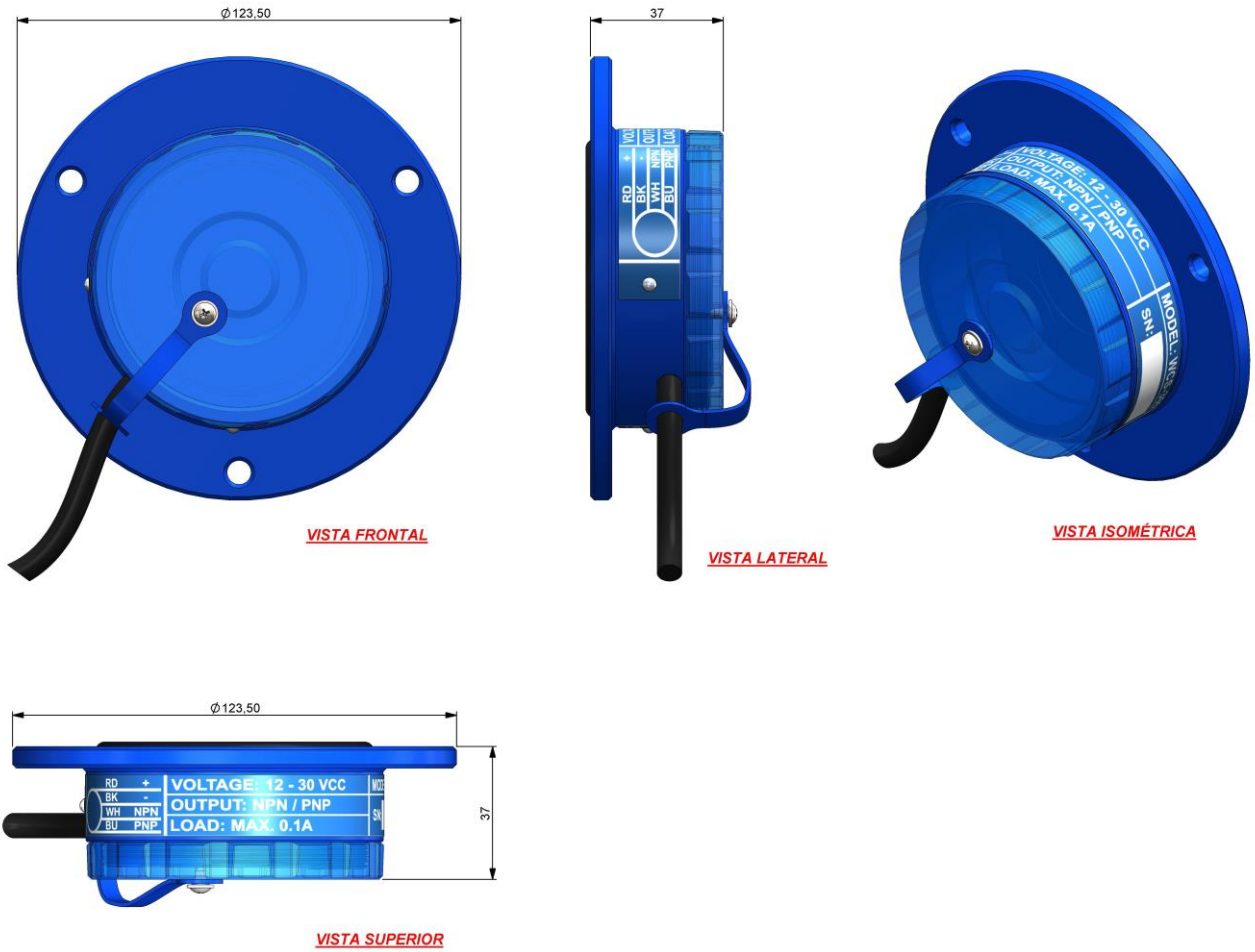

Figure 1 – Mounting Dimensions (mm)

Operation

The WCS-300 is a capacitive proximity sensor, operates with beat frequencies with values close to 1 MHz and despite the small power, has the ease of propagation, primarily through metallic bodies. Installing several sensors on the same surface, interactions may occur between them.

Besides, the WCS-300 detects materials in direct proportion to its mass, in other words, if there is one body close to the sensor with more massive than the material to be measured or detected, adjustment range will be considerably diminished, since the sensor is on the verge of switching.

For these reasons, when the WCS-300 is applied to the measurement, sugarcane level indication, feed systems such as Chute-Donnelly or metallic silos, is necessary to build a non-metallic material area with low-mass to install it.

Do not place the capacitive sensor directly in contact with the part to be measured. Its sensitivity is, in most cases, sufficient to "through" acrylic (or other non-metallic material) and detects the product. This facilitates maintenance and preventing wear of the sensing surface.

Mechanical Installation

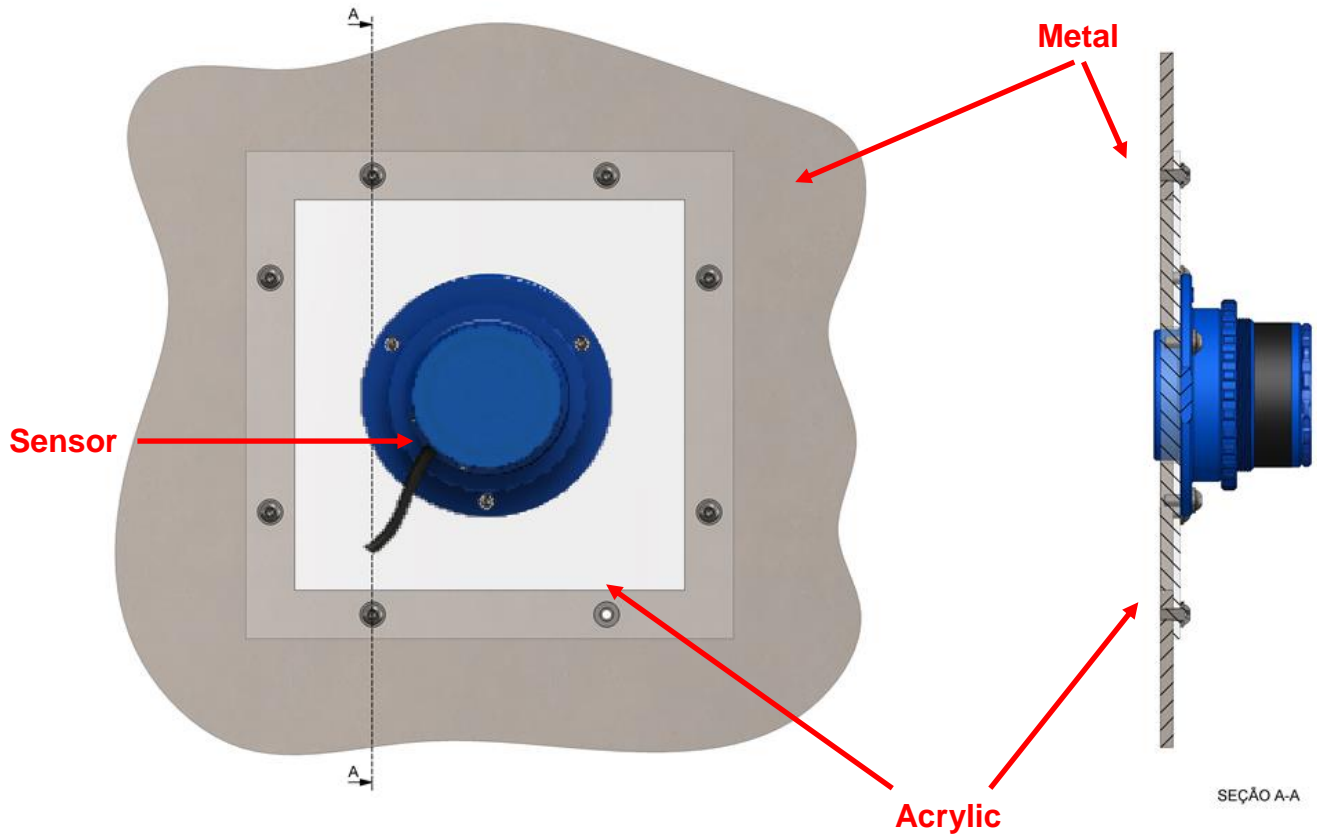

Figure 2 - WCS-300 Installation

Is recommended to use acrylic because of its characteristics, such as:

- low-mass;
- abrasion resistance of sugarcane and other materials;
- transparency that allows viewing of the material to be detected and facilitates sensitivity adjustment;
- possibility of use of existing displays.

The minimum distance between the center of the sensor and the edge of the acrylic should not be less than 100 mm.

Recommended is to install the SC-500 acrylic with a minimum thickness of 10 mm and a maximum thickness of 15 mm.

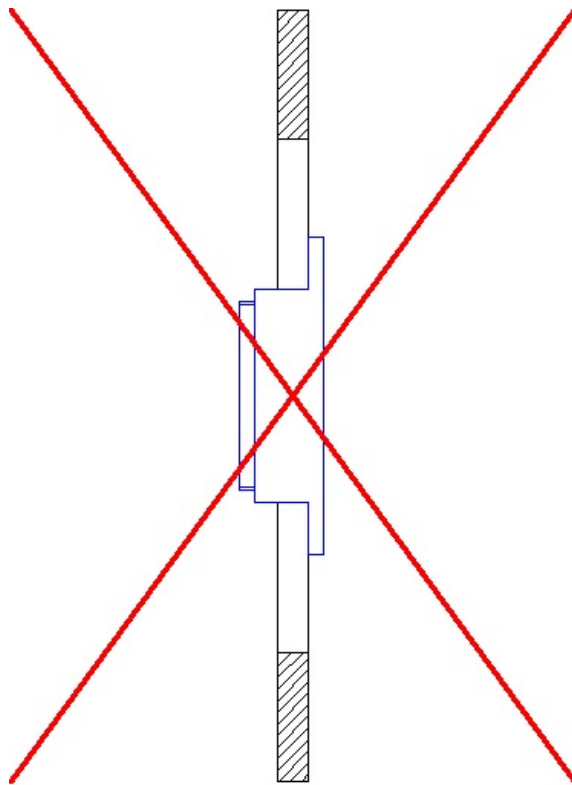

SIDE VIEW

Figure 3 - INCORRECT Installation

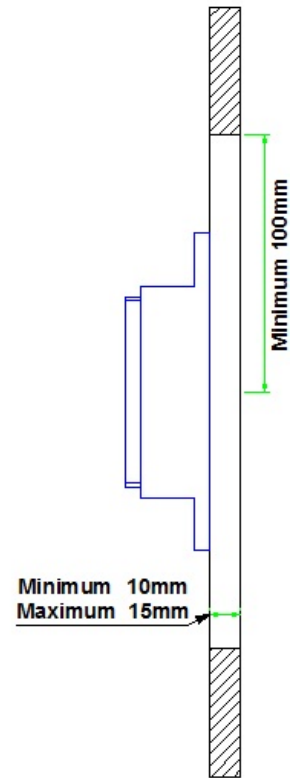

SIDE VIEW

Figure 4 - CORRECT Installation

Electrical Installation

WCS-300

Figures below, show the configuration of the output stages open collector and voltage level, respectively, with indicating color of the connection cables and a simple application example.

Connection	Description
Red (RD)	Input Voltage (+)
Black (BK)	Input Voltage (-)
White (WH)	Out NPN (open collector)
Blue (BU)	Out PNP (digital voltage level)

Connection examples:

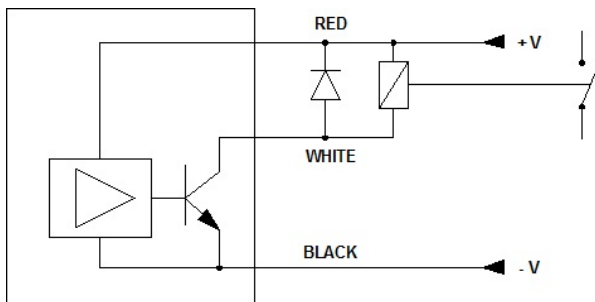

Figure 5 – NPN (OC)

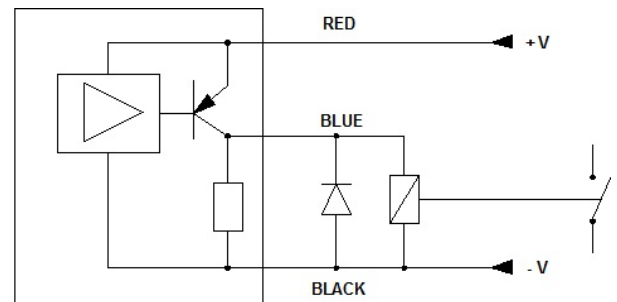

Figure 6 – PNP (VL)

P.S.: It is recommended to install a diode to protect the internal circuitry of the equipment, e. g. **1N4004**.

WCS-300/OPT

Figures below, show the configuration of the output, with indicating color of the connection cables and a simple application example.

Connection	Description
Red (RD)	Input Voltage (+)
Black (BK)	Input Voltage (-)
White (WH)	Out
Blue (BU)	Out

Connection examples:

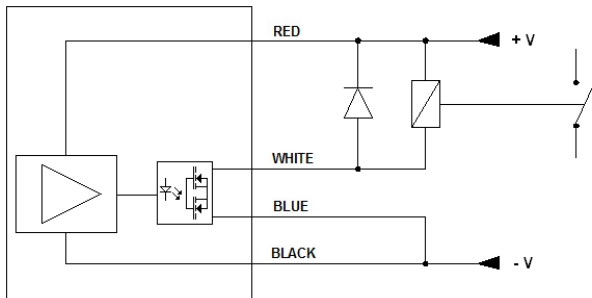

Figure 7 – Switching the negative pole

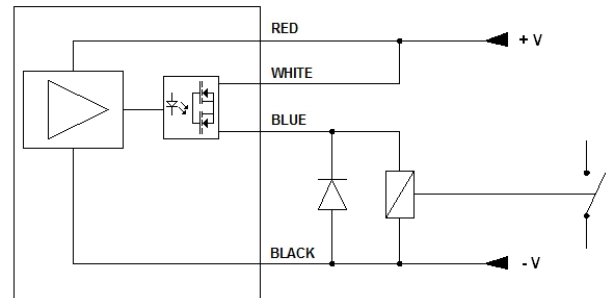

Figure 8 – Switching the positive pole

P.S.: It is recommended to install a diode to protect the internal circuitry of the equipment, e. g. **1N4004**.

Adjustment

The WCS-300 has a sensitivity setting located near the status light (LED), should be removed protective cap to access it.

The sensitivity must be adjusted with the sensor installed and operating in the normal process, noting that it is increased by turning the "trimpot" clockwise.

Warranty

The manufacturer assures to the equipment owners, identified by the purchase invoice, warranty of 1 (one) year as follows:

- 1 - The warranty period begins on the data of the invoice issue.
- 2 - Within the warranty period, the labor and parts used for repairing damage occurred in normal use are free.
- 3 - For repairs, send the equipment along with the shipping invoices to our factory in Sertãozinho, São Paulo state, Brazil. Wirebus's address is available at the end of this manual.
- 4 - The owner is responsible for transportation costs and risks.
- 5 - Warranty will be automatically suspended if changed are made to the equipment by personnel not authorized by Wirebus, defects caused by mechanical shock, exposure to conditions unfit for use or tampering with the product.
- 6 - Wirebus disclaims any charge relating to unauthorized repairs or replacements due to failures caused by agents external to the equipment, the improper use of them and as a result of unforeseeable circumstances or major forces.
- 7 - The Wirebus ensures full operation of the equipment described herein and all existing operations.

Notes

Wirebus

TECHNOLOGY & INNOVATION

Wirebus Technology & Innovation Avenida 21 de Março, 2359 Centro – 14120-000 Dumont – São Paulo – Brasil E-mail: vendas@wirebus.com.br www.wirebus.com.br	MAN-EN-DE-WCS300- 01.00_22	Capacitive Sensor WCS-300
A Wirebus reserves the right to change this manual content without notice in order to keep updating it with potential product developments.		